



# ISO 9001 & AS 9100 REGISTERED

VISIT US ON OUR WEBSITE @ [WWW.PSI-PCI.COM](http://WWW.PSI-PCI.COM)

**P/N 80520-1**

SIZE: 45.65" in ID x 61.12" in length  
 SIZE: 1159.38 mm ID x 1552.32 mm length

Updated August 2011

The propellant tank is an assembly consisting of elliptical domes and a center section cylinder. The tank is mounted via mounting ring that is EB welded and located on the cylindrical portion of the propellant dome. The propellant dome contains both the inlet/pressurization and outlet/drain ports. The tank contains an internally-mounted propellant management device (PMD), with perforated sheet, fabricated to maintain separation of liquid fuel and gaseous pressurant, and to provide predictable gas-free liquid fuel expulsion from the tank under low or zero gravity conditions.

Specification Requirements	Imperial Units		Ref. Temp.		Metric Units		Ref. Temp.		Reference / Note
Operating Pressure	350.00	psia	120.0	°F	24.13	bar	48.9	°C	
Proof Pressure	437.50	psia	120.0	°F	30.17	bar	48.9	°C	
Proof Cycle	437.50	psia	120.0	°F	30.17	bar	48.9	°C	5 cycles
MEOB Cycle	350.00	psia	120.0	°F	24.13	bar	48.9	°C	14 cycles
Design Burst Pressure	700.00	psia	120.0	°F	48.27	bar	48.9	°C	
Total Tank Volume	76,525.00	in <sup>3</sup>	70.0	°F	1254.54	liters	21.1	°C	
Required Propellant Volume	1,960.00	lb	N/A	°F	889.84	liters	N/A	°C	70% fill fraction
Maximum Mass	130.00	lbm			59.09	kg			
Propellant Tube Diameter	0.375	inch			9.53	mm			
Pressurant Tube Diameter	0.250	inch			6.35	mm			
Frequency - lateral	> 40	Hz							
Frequency - axial	> 40	Hz							

### Random Vibration Environments - Empty Tank

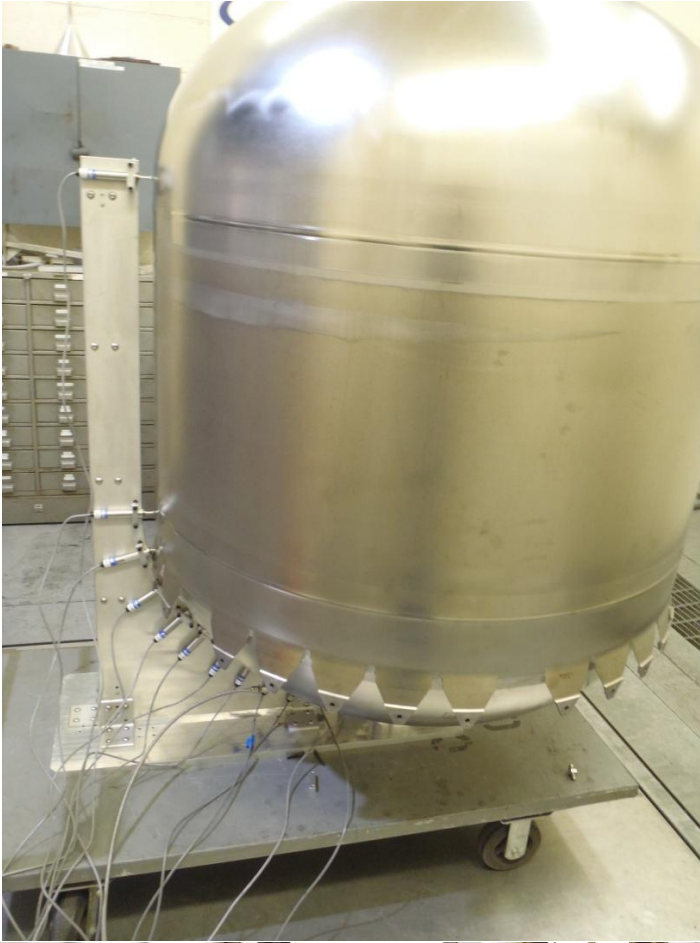
Frequency, Hz	Acceptance Level	Qualification Level	Units
20	0.005	0.02	g <sup>2</sup> /Hz
20 to 50	+9	9	db/octave
50 to 1000	0.075	0.3	g <sup>2</sup> /Hz
1000 to 2000	-6	-6	db/octave
2000	0.0188	0.075	g <sup>2</sup> /Hz
Overall	10.45	20.9	g <sub>rms</sub>
Time per Axis	1	3	Minutes

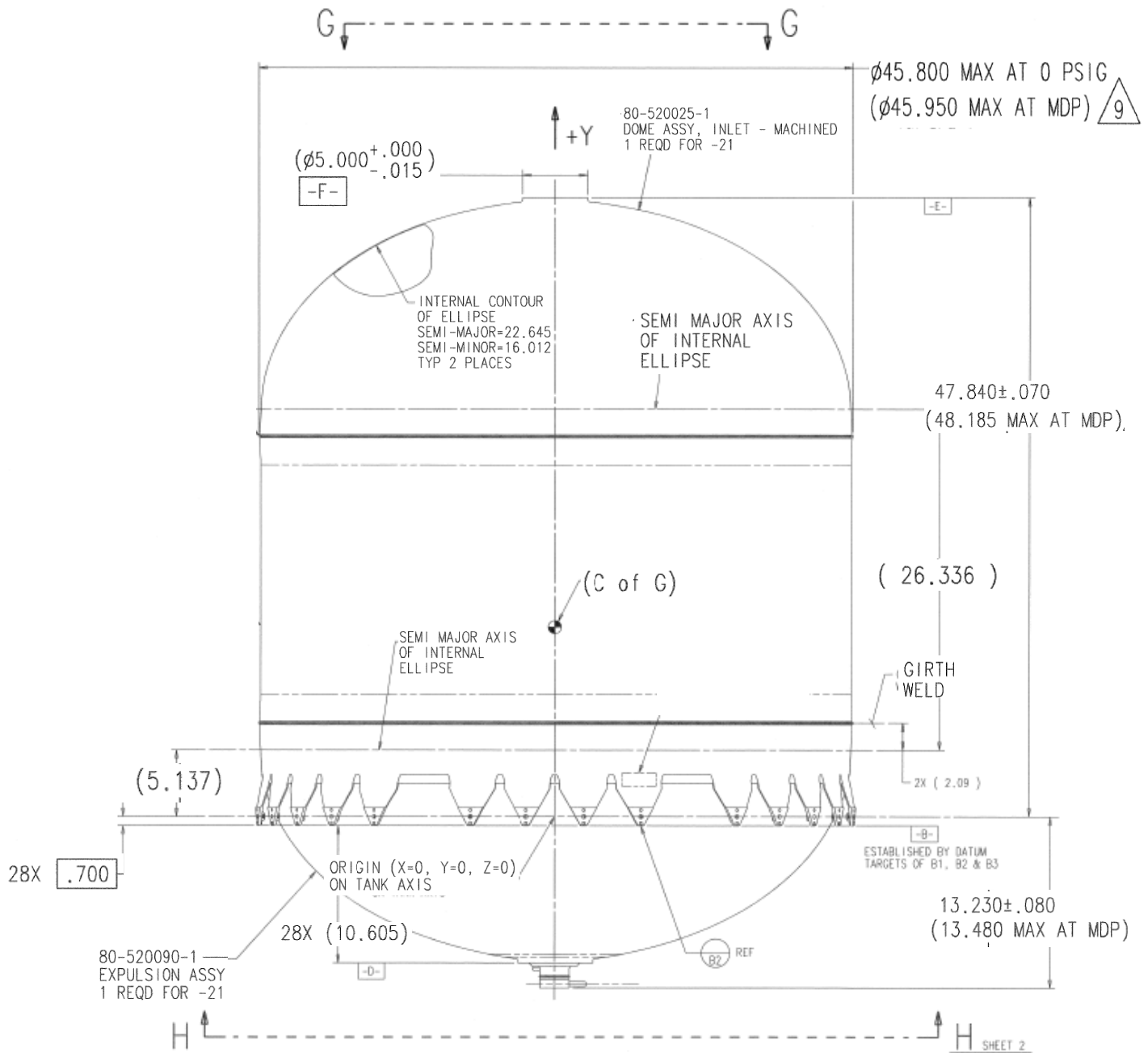
### Random Vibration Environments - Full Tank

Frequency (Hz)	Flight Proof PSD Level (g <sup>2</sup> /Hz)		Qualification PSD Level (g <sup>2</sup> /Hz)	
	Lateral	Axial	Lateral	Axial
20	0.01	0.01	0.02	0.02
50 - 140	0.041	0.041	0.081	0.081
170 - 300	0.02	0.02	0.081	0.081
500 - 1000	0.005	0.005	0.02	0.02
2000	0.001	0.001	0.004	0.004
Overall	3.83 G <sub>RMS</sub>	3.83 G <sub>RMS</sub>	6.96 G <sub>RMS</sub>	6.96 G <sub>RMS</sub>
Duration/ Axis	1 minute	1 minute	3 minutes	3 minutes

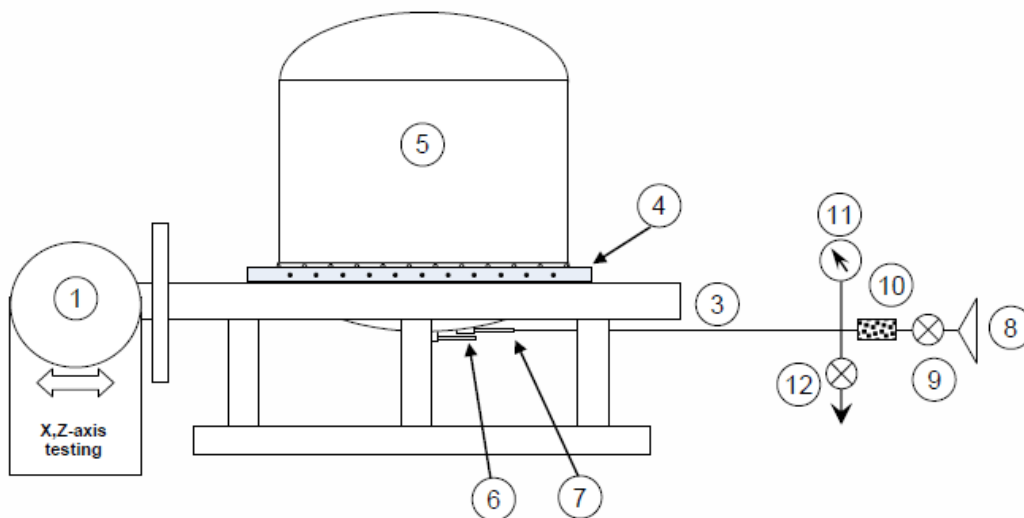
Tank is loaded with approximately 1960 lbm of propellant and pressurized with helium (approximately 3.1 lbm) to MDP

Interface



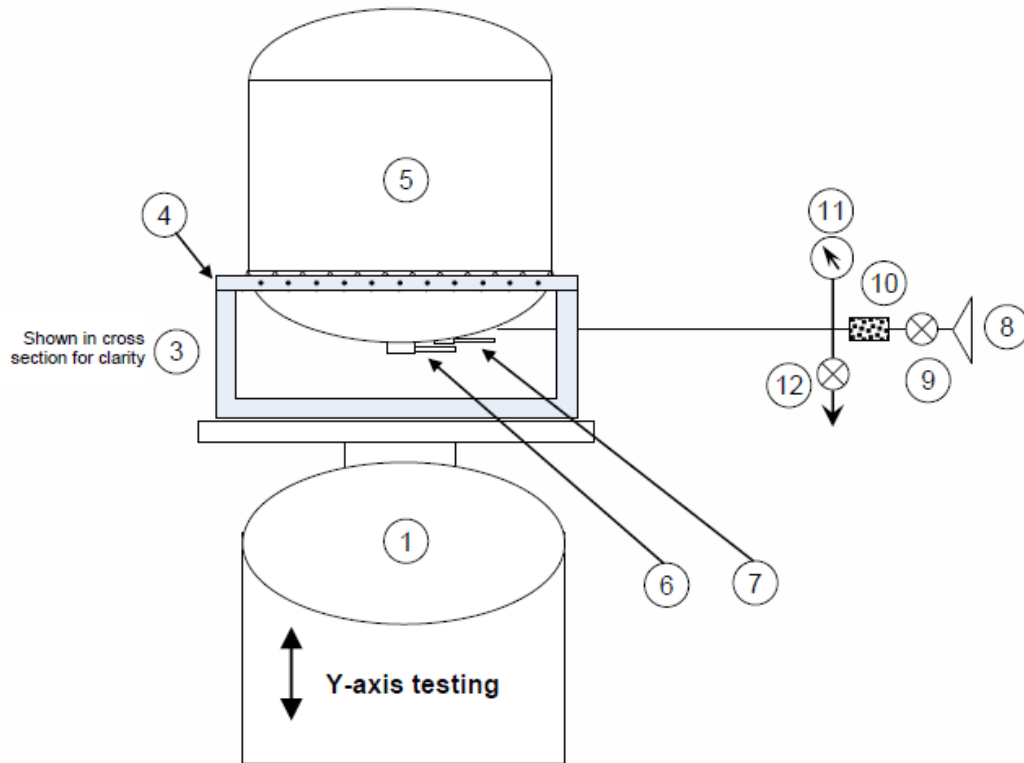


**Figure No. 8– Vibration Test**  
**Lateral Axis**  
**Sheet 1 of 5**



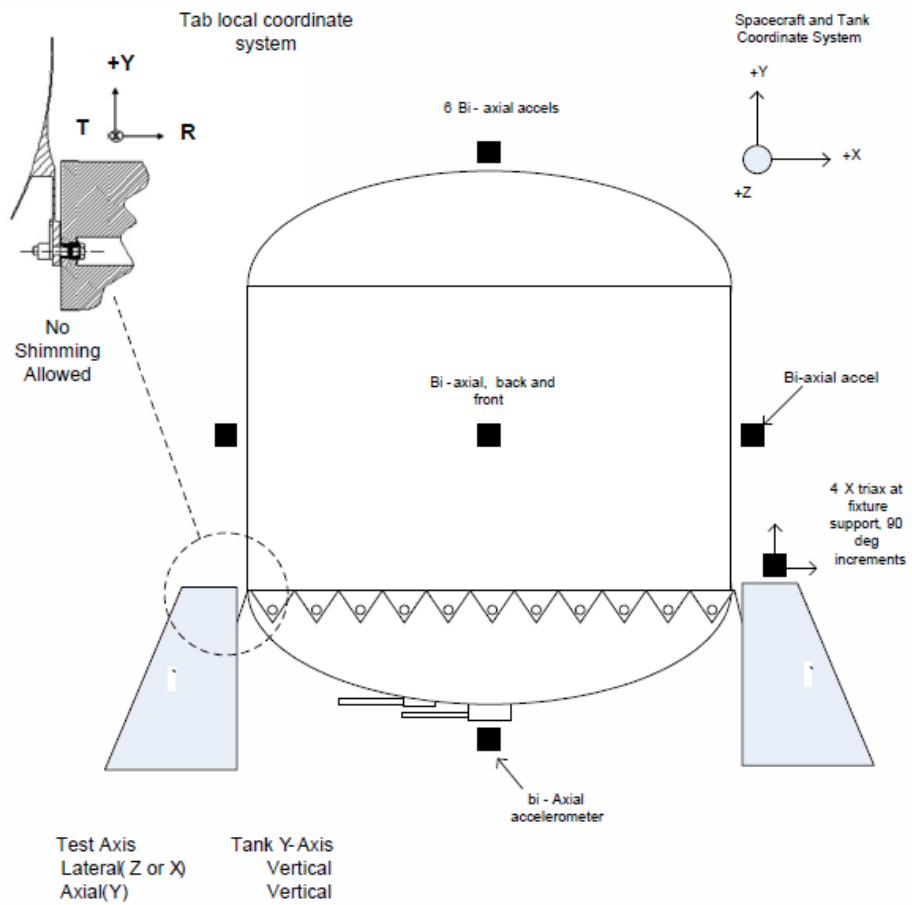
- |   |                            |    |                           |
|---|----------------------------|----|---------------------------|
| 1 | VIBRATION SHAKER           | 7  | PRESSURANT PORT           |
| 2 | DOES NOT APPLY             | 8  | REGULATED NITROGEN SUPPLY |
| 3 | SLIP TABLE                 | 9  | INLET VALVE               |
| 4 | RING ADAPTER 873-6954T-001 | 10 | FILTER                    |
| 5 | PROPELLANT TANK            | 11 | PRESSURE GAUGE            |
| 6 | PROPELLANT PORT, CAPPED    | 12 | VENT VALVE                |

**Figure No. 8 – Vibration Test  
Axial Axis  
Sheet 2 of 5**

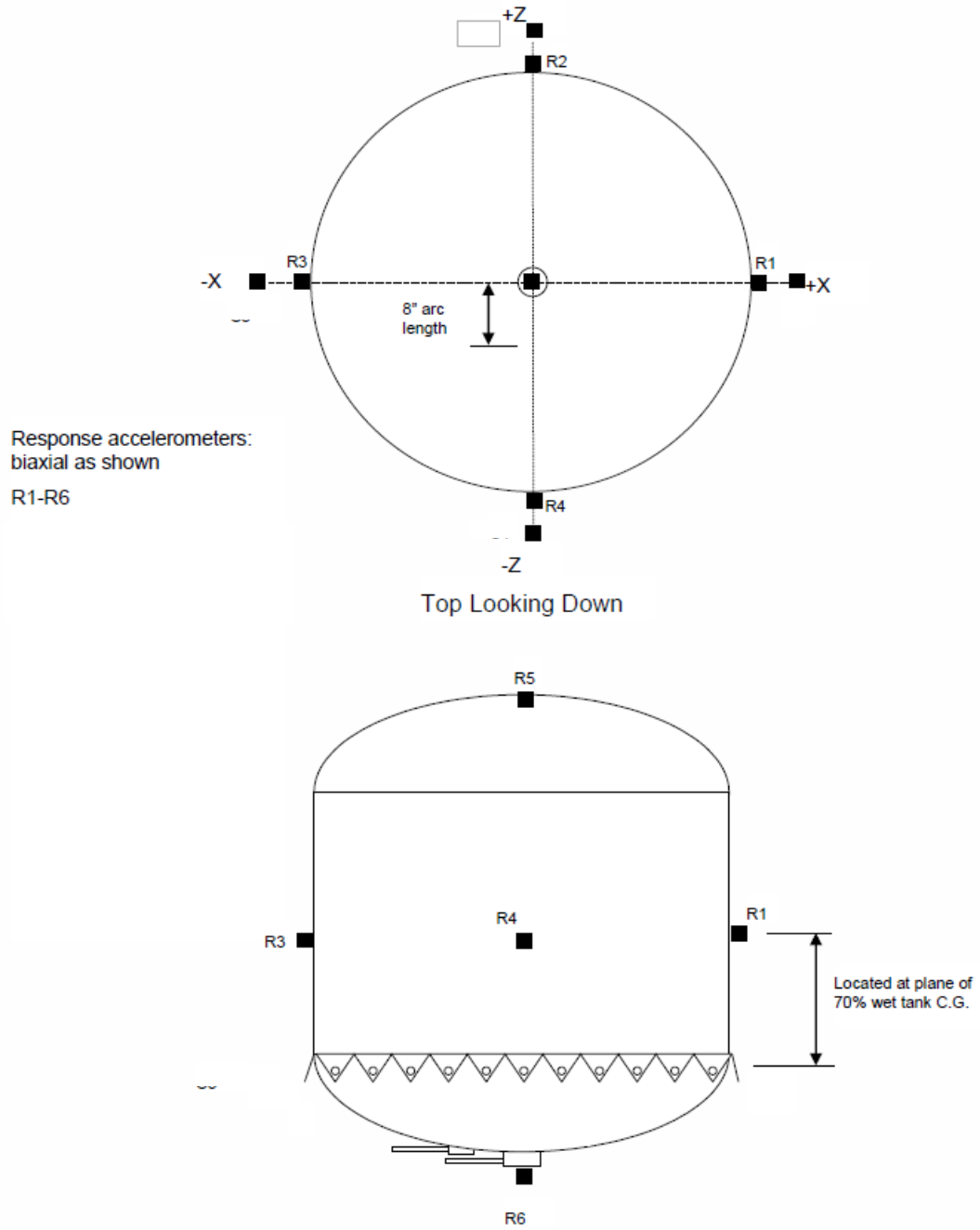


- |   |                                 |    |                           |
|---|---------------------------------|----|---------------------------|
| 1 | VIBRATION SHAKER                | 7  | PRESSURANT PORT           |
| 2 | DOES NOT APPLY                  | 8  | REGULATED NITROGEN SUPPLY |
| 3 | VIBE FIXTURE TUB 873-6954R-002  | 9  | INLET VALVE               |
| 4 | VIBE FIXTURE RING 873-6954T-001 | 10 | FILTER                    |
| 5 | PROPELLANT TANK                 | 11 | PRESSURE GAUGE            |
| 6 | PROPELLANT PORT, CAPPED         | 12 | VENT VALVE                |

**Figure No. 8 – Vibration Test  
Instrumentation Setup  
Sheet 3 of 5**



**Figure No. 8 – Vibration Test  
Instrumentation Setup  
Sheet 4 of 5**



ACCEPTANCE TESTS			Reference Document	Actual Test Data: Serial No. 0301	
Examination of Product	Pass required		50-000715	Pass	Pass/fail
Weight Determination	139	lbs maximum	50-000715	135.01	lbs actual
Pre-Proof Volume Determination	76525	in <sup>3</sup> , record required	50-000715	76622.2	in <sup>3</sup> , record actual
Proof Pressure Test	455	psig, record required	50-000715	459	psig, record actual
Post-Proof Volume Determination	76525	in <sup>3</sup> , record required	50-000715	76622.2	in <sup>3</sup> , record actual
Expulsion Efficiency	N/A	%, record required	50-000715	N/A	%, record actual
PMD Bubble Point Test	Proprietary	Record required	50-000715	Proprietary	Record actual
External Leakage Test	1x10 <sup>-6</sup>	std cc/He maximum	50-000715	3.5x10 <sup>-8</sup>	scc/sec Record actual
Penetrant Inspection	Pass required		50-000715	Pass	Pass/fail
Radiographic Inspection	Pass required		50-000715	Pass	Pass/fail
Final Examination of Product	Pass required		50-000715	Pass	Pass/fail
Cleanliness Verification	Record required		50-000715	Pass	Record actual

QUALIFICATION TESTS			Reference Document	Actual Test Data: Serial No. 0201	
Examination of Product	Pass required		56-000255	Pass	Pass/fail
Weight Determination	139	lbs maximum	56-000255	136.16	lbs actual
Pre-Proof Volume Determination	76525	in <sup>3</sup> , record required	56-000255	76600.4	in <sup>3</sup> , record actual
Proof Pressure Test	455	psig, record required	56-000255	458	psig, record actual
Post-Proof Volume Determination	76525	in <sup>3</sup> , record required	56-000255	76636.4	in <sup>3</sup> , record actual
Proof Cycle	455	psig, record required	56-000255	460	psig, 20 cycles
MEOP Cycle	364	psig, record required	56-000255	369	psig, 84 cycles
Vibration Test, Random	See below for details*				
Expulsion Efficiency	> 99.5	%, record required	56-000255	99.9	%, record actual
PMD Bubble Point Test	Proprietary	Record required	56-000255	Proprietary	Record actual
External Leakage Test	1 x 10 <sup>-6</sup>	std/cc He max,	56-000255	5.3 x 10 <sup>-7</sup>	std/cc He, record actual
Penetrant Inspection	Pass required		56-000255	Pass	Pass/fail
Radiographic Inspection	Pass required		56-000255	Pass	Pass/fail
Final Examination of Product	Pass required		56-000255	Pass	Pass/fail
Cleanliness Verification	Record required		56-000255	Pass	Record actual
Burst Pressure Test	546	psig, record required	56-000255	663	psig, record actual

Natural Frequency			
Axis	Requirement	FEM Analysis Prediction	Actual Frequency
X	> 40 Hz	103.9 Hz	106 Hz
Y	> 40 Hz	103.9 Hz	106 Hz
Z	> 40 Hz	107.3 Hz	106 Hz

Tank is loaded with 1960 lbm of DI water and pressurized to 364 psig.

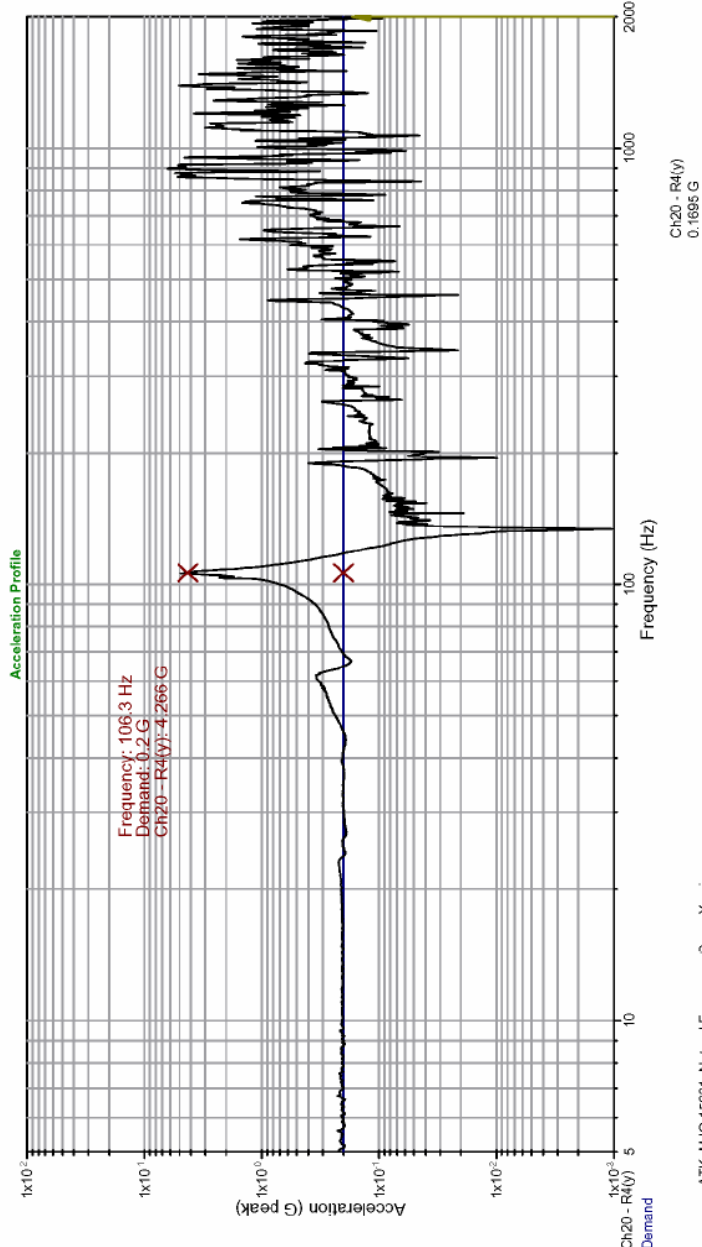
*Dry Sine Sweep (Empty tank and pressurized)		
Axes	Frequency (Hz)	Acceleration
X & Y (lateral)	5 - 50	0.5g
	50 - 60	0.2g
	60 - 120	0.2g
Z (axial)	5 - 50	0.1g - 0.5g
	50 - 120	0.5g

*Natural Frequency - Tank loaded and pressurized		
Axes	Frequency (Hz)	Acceleration
X,Y,Z	5 - 2000	0.2g

Sweep rate of 2 oct/min @ 70% fill fraction



1 of 1 sweeps complete  
Sweep between 5 Hz and 2000 Hz at 2 Oct/min  
Elapsed Time: 0:04:28  
Current Frequency: 2000 Hz  
Points Per Sweep: 2000 points  
Mar 31, 2011 14:03:09



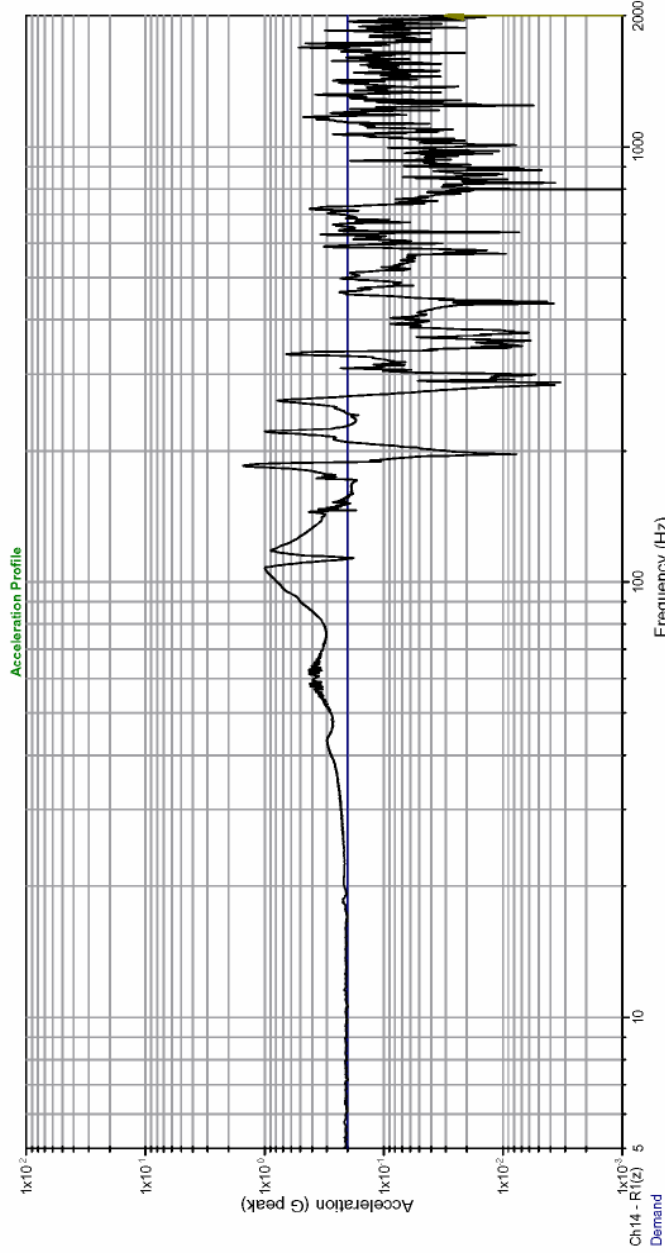
ATK\_MJO:15201, Natural Frequency Scan, Y-axis  
Propellant Tank, pn: 80520-11, sn: 0201, Plot #638

Test Name: C:\Vibration\VIEWProfiles\ATK15201\15201 Sine Survey.vsp Data Directory: ATK15201  
File Name: C:\Vibration\VIEW\Data\ATK15201\Natural Frequency Scan, Y-axis, SN0201\2011-03-31\_14\_03\_09\_0.dB vsd

Mar 18, 2011 14:16:23  
Points Per Sweep: 2000 points

Elapsed Time: 0.0420  
Current Frequency: 2000 Hz

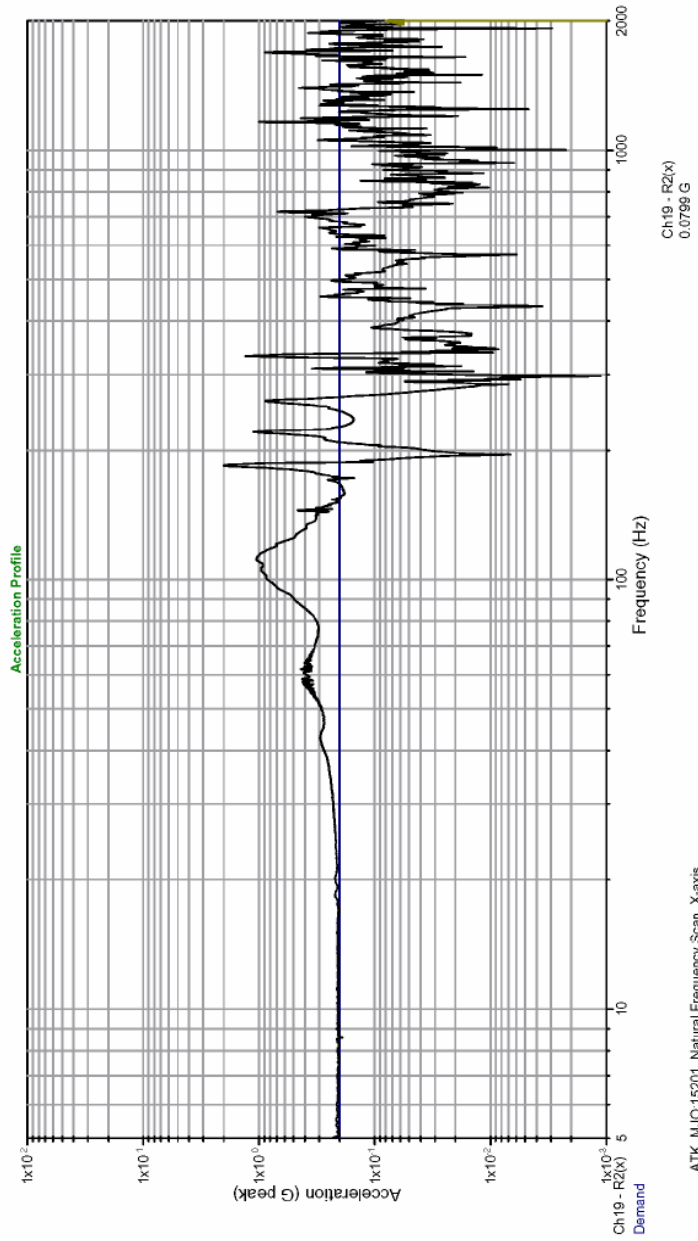
1 of 1 sweeps complete  
Sweep between 5 Hz and 2000 Hz at 2 Oct/min



ATK\_MJO:15201\_Natural Frequency Scan, Z-axis  
Propellant Tank, pn: 80520-11, sn: 0201, Plot#305

Test Name: C:\Vibration\VIEW\Profiles\ATK15201\15201\_Sine\_Survey.vsp Data Directory: ATK15201  
File Name: C:\Vibration\VIEW\Data\ATK15201\Natural\Frequency Scan, Z-axis\2011-03-18\_14\_16\_23\_0.dB.vsd

1 of 1 sweeps complete  
Sweep between 5 Hz and 2000 Hz at 2 Oct/min  
Elapsed Time: 0:04:20  
Current Frequency: 2000 Hz  
Mar 18, 2011 15:10:32  
Points Per Sweep: 2000 points



ATK\_MJO:15201, Natural Frequency Scan, X-axis  
Propellant Tank, pn: 80520-11, sn: 0201, Plot#335

Test Name: C:\Vibration\VIEW\Profiles\ATK15201\15201\_Sine\_Survey.vsp Data Directory: ATK\15201  
File Name: C:\Vibration\VIEW\Data\ATK15201\Natural Frequency Scan\_X-axis\2011-03-18\_15-10-32\_0 dB.vsd

**Burst Pictures**

